

The Birch

WILDRIDGE TOWNHOMES

3 Bedroom • 2.5 Bath • Outdoor Living

2 Story • 1,840 sq. ft.

1ST FLOOR



2ND FLOOR



9' Ceiling
Higher Where Noted



PLAN 2221-G

GRENADIER HOMES

Floorplans are subject to change. There may be small differences between the plan shown and the final product purchased. We endeavor to continually improve our plans and processes, so please consult your sales counselor or the Grenadier Homes website for the most current version of this plan.

DATE: 06/27/2025



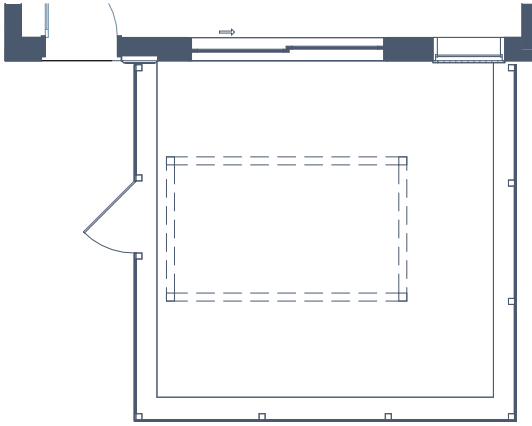

OPTIONAL TRELLIS

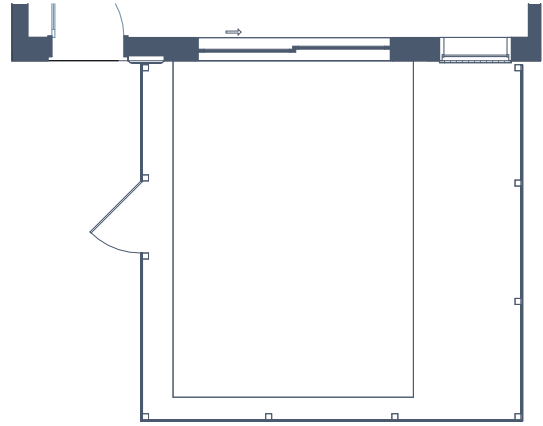

OPTIONAL TURF

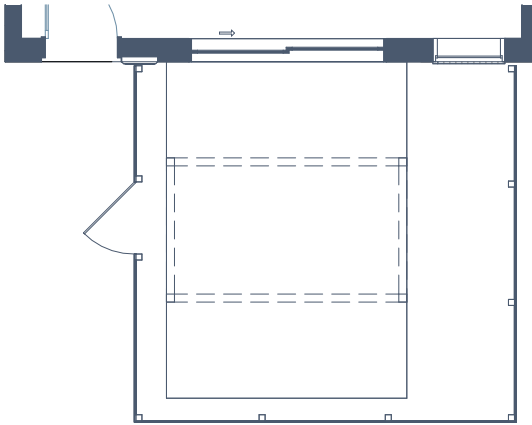

OPTIONAL TURF & OPTIONAL TRELLIS

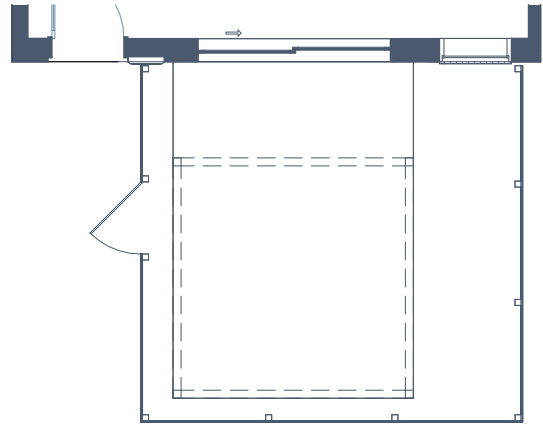

OPTIONAL TURF & OPTIONAL EXTENDED TRELLIS



OPTIONAL ELECTRIC FIREPLACE

